

HEE-IZR series Roof Mounted Exhaust Fan

HEE-100/150/200/250/280IZR

Product Features

This roof mounted exhaust fan is designed for residential, commercial and industrial ventilation applications.

- ◆ The fan body is assembled with weatherproof and ultraviolet-proof thickened cowl and galvanized steel plate base and mesh.
- ◆ Low profile and fashionable fan body outlines.
- ◆ A powerful motor with backward centrifugal blade is used to this fan, it produces big airflow and big air pressure.
- ◆ It must be horizontally mounted.

Performance Parameter

Model No.	Voltage (V)	Frequency (Hz)	Current (Amps)	Power (W)	Speed (RPM)	Airflow (m ³ /h)	Air Pressure (Pa)
HEE-100IZR	220~240	50	0.17	37	2900	273	206
HEE-150IZR	220~240	50	0.26	61	2650	557	409
HEE-200IZR	220~240	50	0.35	82	2600	781	572
HEE-250IZR	220~240	50	0.74	149	2600	1152	556
HEE-280IZR	220~240	50	1.03	237	2700	1811	834



Performance Curves

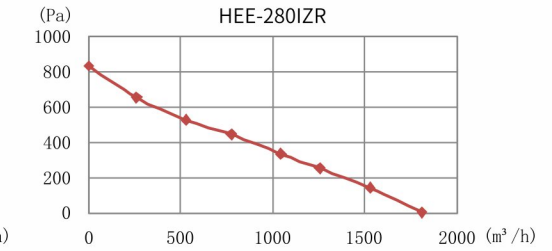
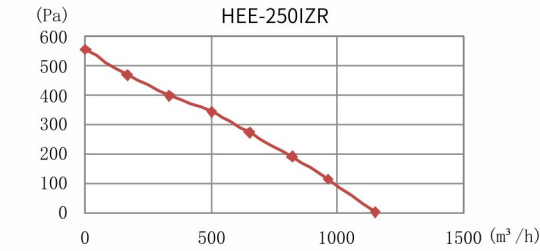
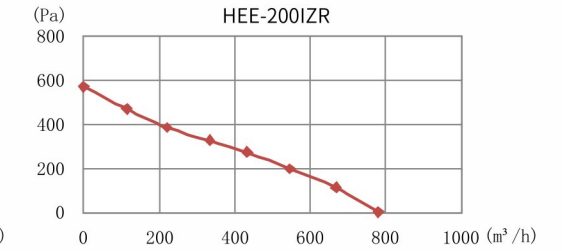
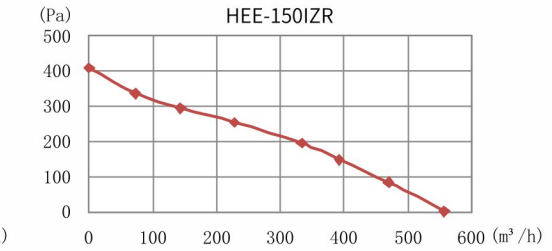
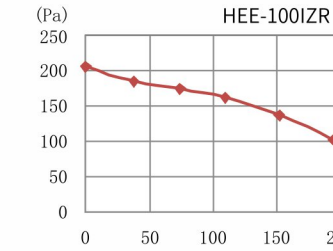

Dimensions(mm)

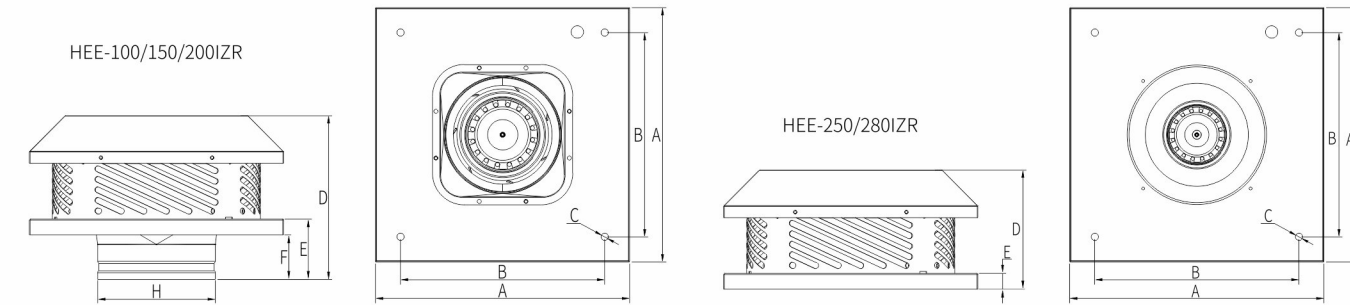

Model	A	B	C	D	E	F	H
HEE-100IZR	285	245	Φ9	198	63	43	Φ96
HEE-150IZR	320	257	Φ9	206	76	56	Φ148
HEE-200IZR	360	297	Φ9	223	70	50	Φ198
HEE-250IZR	420	357	Φ9	197	20	/	/
HEE-280IZR	450	387	Φ9	203	20	/	/